



# UTILITY PAILS

AVAILABLE IN 6 SIZES AND  
9 STANDARD COLORS



[www.polypails.com](http://www.polypails.com)

# 8 TEAR TAB LID

Made to fit the following pails:  
3.5, 4.25, 5 Gallon, 20 Liter, 6 Gallon

## SPECIFICATIONS



THIS LID IS IDEAL FOR THE FOLLOWING USES:

Non-hazardous solids and liquids such as paint, mortar, and food

Please contact customer service at 800-962-6788 or e-mail [customerservice@polyconainers.net](mailto:customerservice@polyconainers.net) for additional information such as the full trailer pack out configuration options and product specifications.



UN solid rated certified lid available. Please ask your sales representative for more details.

## FEATURES

- Lids are manufactured using high quality 100% recyclable HDPE resin
- Gasket Options: Ethylene Propylene Diene Monomer (EPDM), Styrene Butadiene Rubber (SBR)
- Lid Fitting Options: blank panel tint plug, metal crimp-on spout, all-plastic spout, 70 mm screw cap, 70 mm screw cap with tint plug buna vent, PVI vent, vented rieke (metal and all-plastic) vented
- National Motor Freight (NMF) certification

## COLOR

The following standard pail colors are available. Custom colors are available upon request.

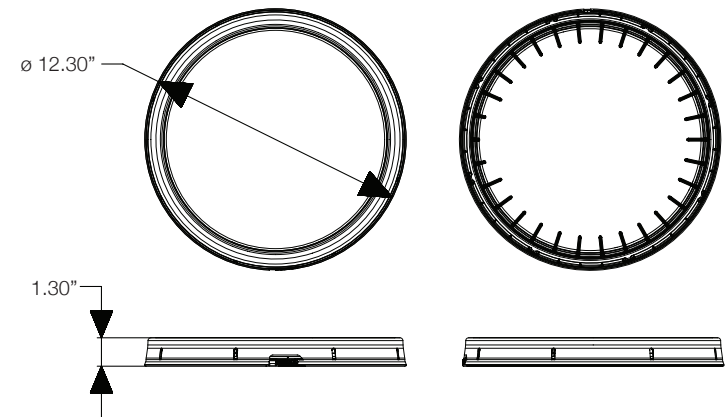

Item	Weight (lb)	Pkg	Qty Per Pallet	53' Trailer fs/ftl qty
Lid	0.65	Tray		
Lid	0.65	Tray		